

Two Quantitative Assays for Chemotaxis in *Paramecium*

Judith Van Houten and Helen Hansma

Department of Biological Sciences, University of California,
Santa Barbara, California, USA

Ching Kung

Laboratory of Molecular Biology and Department of Genetics,
University of Wisconsin, Madison, Wisconsin, USA

Received August 18, 1975

Summary. We present two new methods to quantify the attraction and repulsion of *Paramecium aurelia* by chemicals. These are a T-maze assay and a countercurrent separation assay.

In the T-maze assay, cells were placed in one arm of a three-way stopcock. The cells were then allowed to enter the other two arms, one of which contained an attractant or repellent. The ratio of cells collected from these two arms was an index of chemotaxis. The reproducibility of this method was demonstrated, using potassium acetate to study attraction (positive chemotaxis), and quinine-HCl to study repulsion (negative chemotaxis). This method is rapid and convenient.

The countercurrent separation assay was adapted from the method of Dusenbery (1973), originally used to study behavior in nematodes. Animals were injected into the center of a slanted tube through which two solutions of different densities were pumped in opposite directions. One solution contained an attractant or repellent. Animals emerging from the tube in each of the two solutions were counted. These counts were used to measure the extent of chemotaxis. This method is useful for studying attraction in populations of over 10^4 paramecia and for isolating mutants defective in chemotaxis.

Introduction

The classic work of Jennings (1967) leaves no doubt that protozoa can detect chemicals in the environment and be attracted or repelled by them. Such responses in microorganisms are generally known as chemotaxis. However, in the terminology of Fraenkel and Gunn (1961), paramecia may show a chemokinesis rather than a true chemotaxis, in which the cells orient and move directly toward or away from the stimulating chemicals. Instead, in chemokinesis, the stimulus causes a change in motor behavior of the cell but does not cause orientation of the cell toward the stimulus. As the mechanism is unknown and this paper deals with assays alone, we will continue with the traditional use of chemotaxis for chemo-accumulation and de-accumulation of *Paramecium*.

Impetus to study chemotaxis in *Paramecium* comes partly from the recent advances in the study of the chemoreception in other systems: aggregation of amoebas to form the plasmodial slug, mediated through cyclic AMP (Konijin *et al.*, 1967); the migration of leucocytes to inflammatory sites (Wilkinson, 1974); accumulation and repulsion of *Escherichia coli* by various chemicals (Adler, 1969; Hazelbauer *et al.*, 1969; Adler *et al.*, 1973); and more recently of *Salmonella* (Dahlquist *et al.*, 1972; Tsang *et al.*, 1974).

Further impetus for the study of chemotaxis in *Paramecium* comes from recent developments in the genetics of behavior of *P. aurelia*. Kung and co-workers have succeeded in isolating over 300 lines of behavioral mutants at 20 genetic loci, each with a defect in the stimulus-response pathway (Kung *et al.*, 1975). A study of wild type chemotaxis and chemotactic mutants will provide valuable additions to the dissection of the control of behavior of *P. aurelia*.

A basic requirement for studying chemotaxis is to have a reliable assay for quantitating this behavior. Such an assay has not previously been reported. Chemotaxis in *Paramecium* was first studied systematically by Jennings in 1906 (Jennings, 1967). He observed the aggregation of cells in drops of different solutions on microscope slides. This method has been refined by Dryl (1963, 1973). Nakatani (1968, 1970) has assayed chemotaxis in *Paramecium* by measuring the accumulation of cells in capillaries filled with different solutions. Both of these methods are semi-quantitative and no statistical analysis has yet been performed on the data.

We have, therefore, developed and evaluated two new methods to quantify chemotaxis in *P. aurelia*. One is the T-maze assay, which is simple, rapid, and reproducible. The other is a countercurrent separation assay (Dusenbery, 1973, 1974), which is used to test the behavior of large populations of cells.

Materials and Methods

Cell Culture. *P. aurelia*, syngen 4, stock 51-s, was grown at room temperature in cerophyl medium bacterized with *Aerobacter aerogenes* (Sonneborn, 1950).

Solutions. The following "base solution" was used in some of the T-maze experiments: 1 mM Tris, 1 mM Citric acid, 1 mM Ca(OH)₂, Potassium acetate (KOAc) as attractant and potassium chloride (KCl) as control were added to this base solution and adjusted to pH 7.05 with Tris to form the "test solution" and the "control solution", respectively.

In other experiments we used Dryl's solution (1 mM Na₂HPO₄, 1 mM NaH₂PO₄, 2 mM Na citrate, 1.5 mM CaCl₂, pH 7.0) (Dryl, 1959) and Dryl's solution supplemented with an attractant (KOAc), the control (KCl) or a repellent (quinine-HCl).

T-Maze (Fig. 1). Three-way stopcocks (Corning No. 441292) with 4 mm i.d. and 11.5 cm arms were modified for this purpose. The center arm (the "entry arm", E in Fig. 1) was cut to 4.8 cm. The side arms ("the test arm", T, and the "control arm", C in Fig. 1) were left intact. The volume of solution in the entry arm was 1.4 ml, that of the test arm and control arm were 3.7 ml each; and the volume within the stopcock was 0.1 ml.

The T-Maze Assay. A typical experiment began by filling the control arm and the small space inside the stopcock bore with the control solution. The stopcock was then closed and the control arm sealed with a cork. Next, the test arm was filled with the test solution and stoppered. 25 ml of cell culture were centrifuged at 350 × g for 2 min in an oil testing centrifuge (International Equipment Co. HN-S). The pellet was resuspended in control solution to a 100–200 fold dilution. One ml of this suspension, containing 500–700 cells, was pipetted into the entry arm. This arm was then filled with more control solution and its end sealed. Care was taken to remove large air bubbles especially in the space within the stopcock plug. The T-maze was placed horizontally on a stand to prevent flow and convection. The stopcock was opened gently and the test was allowed to run for 30 min before the stopcock was closed again. Arms and plug were emptied into separate tubes. Cells were counted in two or more 1 ml aliquots from each tube with a micropipette under low power stereomicroscope.

We used two indices to characterize the behavior in the T-maze: the index of chemotaxis (I_{che}) and the index of motility (I_m). They are defined as follows: $I_{che} = \frac{T}{T+C}$, where T = number of cells in the test arm, C = number of cells in the control arm. $I_{che} > 0.5$ indicates

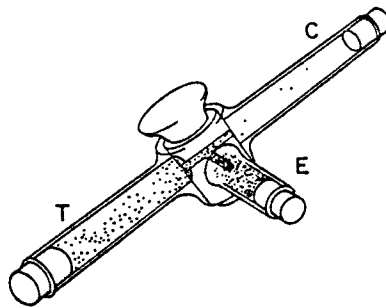

Fig. 1. T-maze for assaying chemotaxis. *Paramecia* are placed in the "entry arm", *E*, test solution in the "test arm", *T*, control solution in the "control arm", *C*, and the stopcock in the center. The relative number of *paramecia* found in *T* after 30 min measures chemotaxis

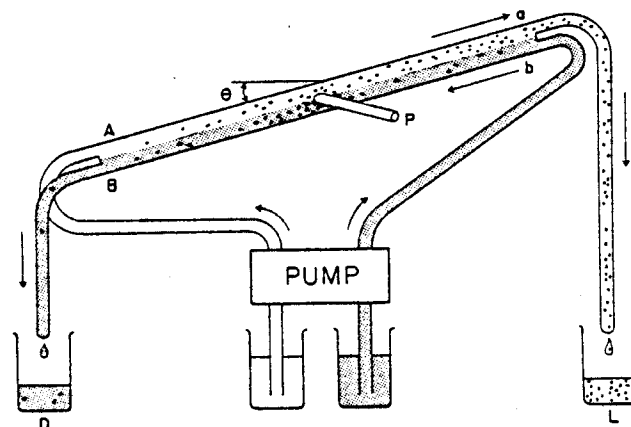

Fig. 2. Countercurrent apparatus for assaying chemotaxis. The dense solution (shaded) is pumped into the bottom of the raised end of the tube (*b*) and is collected at the bottom of the lower end of the tube (*B*). The light solution is pumped into the top of the lower end of the tube (*A*) and is collected from the top of the raised end of tube (*a*). Arrows show the direction of fluid flow. The *paramecia* (dots) are injected at *P*, and allowed to distribute into the two currents of solutions. The relative numbers of *paramecia* emerging in the dense solution and the light solution measure chemotaxis when one of the solutions contains an attractant or a repellent

attraction (positive chemotaxis); $I_{che} < 0.5$ indicates repulsion (negative chemotaxis). $I_m = \frac{T+C}{\text{Total cells}}$. I_m measures the fraction of cells moving out of the entry arm, *E*.

Countercurrent Apparatus (Fig. 2). This apparatus was adapted from that used by Dusenbery (1973) to study chemotaxis in nematodes. Two solutions of different densities flowed past each other in opposite directions through a tube. One solution contained an attractant or repellent. The *paramecia* in a small volume of a solution of intermediate density were injected at the center of the tube. The cells swam back and forth between solutions and were eventually carried with the solutions out of the tube. The relative numbers of cells appearing in the two effluent solutions was a measure of the extent of chemotaxis.

The basic principle of this separation is similar to the countercurrent extraction technique for separating compounds on the basis of their different relative solubilities in two solvents. Similarly, the *paramecia* have different affinities for the two solutions in the countercurrent apparatus.

The countercurrent tube (Fig. 2) was made from glass tubing, 5 mm i.d. and 40 cm long. The inlets and outlets were metal tubing, 1 mm i.d. and 2.5 cm long. The countercurrent tube was mounted at an angle, θ , of approximately 15° . The two solutions were pumped through the tube at 0.7 ml/min with a Buchler Polystaltic pump.

The light solution was Dryl's solution. The dense solution was Dryl's solution supplemented with sucrose (20 mg/ml) to raise the density and bromphenol blue (2.5–5 μ g/ml) to show the interface between the two solutions. An attractant or repellent was added to one of the two solutions, as specified. To establish the countercurrents the tubes were first filled with the light solution, then the dense solution was pumped in.

Countercurrent Separation Assay. Paramecia in culture medium were diluted ten fold with Dryl's solution and concentrated by centrifugation ($350 \times g$, 2 min). The cell pellet was resuspended in a sucrose concentration of 10 mg/ml. The final cell density averaged 8,000–10,000 cells/ml.

One ml of this cell suspension was injected into the center of the tube (P), and the effluent solutions from both ends were collected for 40 min. The number of cells that emerged in the dense solution and in the light solution and those remaining in the column were counted.

Each experiment consisted of two countercurrent tubes to compensate for the asymmetry of the system. In tube 1, the attractant or repellent chemical was in the light solution, while in tube 2, it was in the dense solution. The extent of chemotaxis was defined as follows:

Extent of Chemotaxis = $1/2 \left(\frac{L_1}{L_1 + D_1} + \frac{D_2}{L_2 + D_2} \right)$, where: L = the number of paramecia emerging in the light solution, D = the number of paramecia emerging in the dense solution; subscripts indicate tube numbers.

The extent of chemotaxis, like the I_{che} above, can vary from 0 (total repulsion) to 1 (total attraction); a value of 0.5 shows a complete lack of either attraction or repulsion.

All experiments were performed at room temperature.

Results

T-Maze Assay

Acetate was found to be a strong attractant among many chemicals tested. Details on our search for attractants and repellents as well as the isolation of mutants defective in chemotaxis will appear elsewhere.

Attractant Concentration. To test the relation of attraction to concentration of potassium acetate (KOAc), the test arm of the T-maze was filled with the test solution containing various concentrations of KOAc. For each test, an equal concentration of potassium chloride (KCl) in the base solution was added to the control arm, the entry arm and the plug in the center. Therefore, only the anions (acetate vs. chloride) were different in the test solution and control solution in each test. These tests were run for 30 min with 500 to 700 cells per test (see below).

Chemoaccumulation increased with increasing concentrations of KOAc up to 5 mM (Fig. 3). The Mann-Whitney U test showed no difference for the I_{che} to 5 mM, 7.5 mM and 10 mM KOAc. The accumulation of paramecia in the test arm was not accidental or due to the increase in ionic strength alone. If the test arm was filled with the control solution, as the control arm was, paramecia were found to distribute evenly between the two. Experiments with KCl ranging from 0.1 to 10 mM all gave I_{che} around 0.5 (Fig. 3). However, the motility of the paramecia was affected by the concentrations of both KOAc and KCl (Fig. 4). The number of paramecia moving out of the entry arm of the T-maze increased as the concentration of KCl or KOAc increased up to 5 mM. Further increase in the concentration of KCl or KOAc retarded the movement.

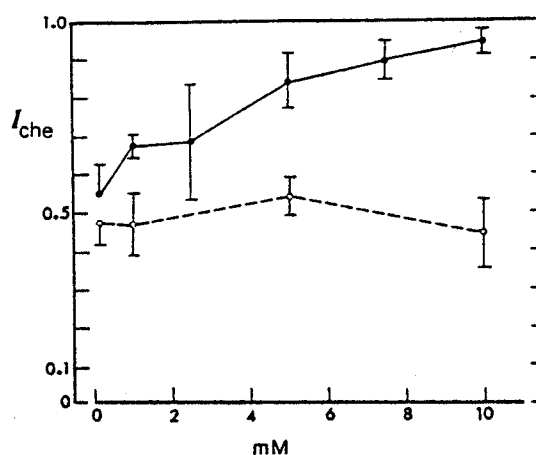

Fig. 3. Attraction to acetate in T-maze. Closed circles are tests with test solutions containing specified amounts of potassium acetate (KOAc) and with the same concentration of potassium chloride (KCl) in the control and entry arms. $I_{che} > 0.5$ indicates attraction of paramecia to the test arm. Open circles are control experiments with KCl of specified concentration in all arms. $I_{che} = 0.5$ is expected when there is not attraction or repulsion. Data given are mean \pm standard deviation; numbers of experiments, n , are 4 to 19. See *Materials and Methods* for solutions, procedures, and the definition of I_{che} . The first data point is at 0.1 mM KCl or KOAc

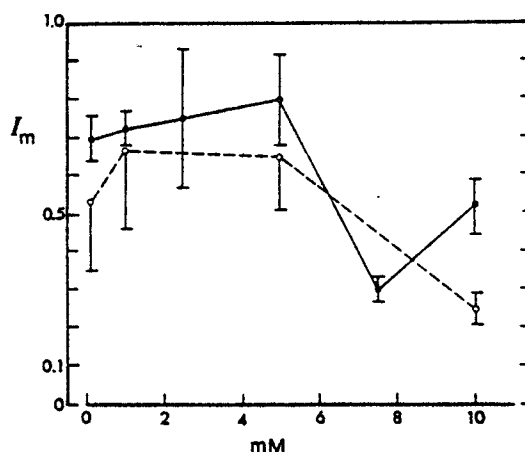

Fig. 4. Motility during chemotaxis in T-maze. Closed circles are tests of attraction to specified concentrations of KOAc in the test arm with the same concentration of KCl in the control and entry arms. Open circles are control experiments with specified concentrations of KCl in all arms. I_m indicates the fraction of paramecia moving out of the entry arm. Data were collected from the same set of experiments in Fig. 3. See legend of Fig. 3 and *Materials and Methods* for solutions, procedures, and the definition of I_m . The first data point is at 0.1 mM KCl or KOAc

Time Course. We terminated the attraction experiments at different times to find the time needed for the paramecia to migrate into the test arm. Here we used 5 mM KOAc as attractant. After 15 min, most of the paramecia had moved out

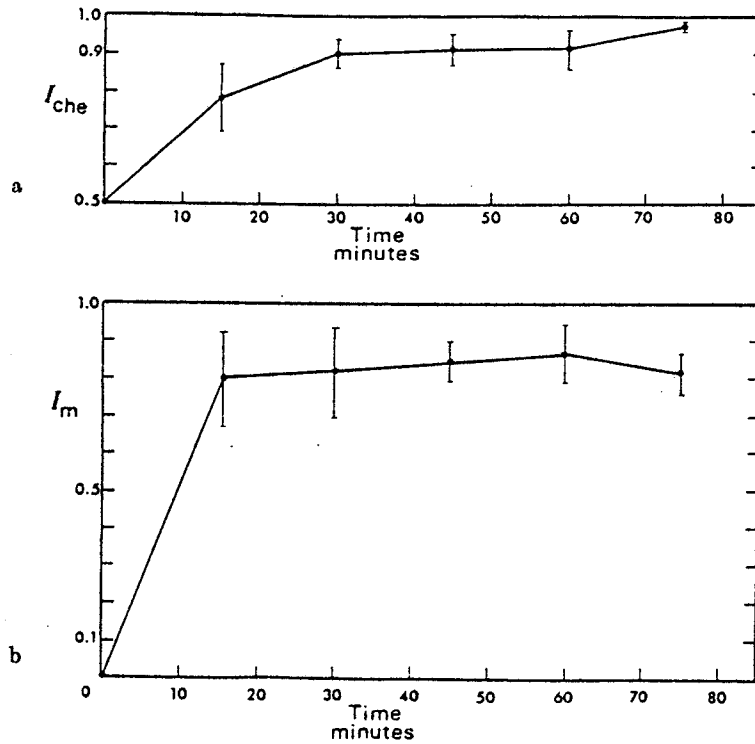

Fig. 5. Time course of attraction by 5 mM acetate in T-maze. I_{che} and I_m are plotted against duration of the experiments. 5 mM KOAc-supplemented test solution is in the test arm, 5 mM KCl-supplemented control solution is in the rest of the T-maze. Mean \pm standard deviation; $n=8$. See *Materials and Methods* for solutions, procedures and the definitions of I_{che} and I_m .

of the entry arm (Fig. 5b) and into the test arm (Fig. 5a). As shown in Fig. 5 there were no net migrations of paramecia among the arms after 30 min. Therefore, 30 min was chosen as the minimum for further experiments.

Thirty minutes were enough for migration to reach equilibrium even when no attractant was used. When all arms contained 5 mM KCl in base solution, no increase in net emigration from the entry arm was seen from 30 min ($I_m=0.76 \pm 0.09$, $n=4$) to 75 min ($I_m=0.70 \pm 0.09$, $n=4$) (Fig. 4). In such experiments where attractant was absent, the I_{che} was near 0.5 at all times, as expected (Fig. 3).

Growth Conditions. We examined paramecia in three different nutritional states for their response to the attractants. Such states are easily identifiable in the laboratory. These states were: well-fed (large, actively dividing cells); medium-fed cells (large cells, but few dividing ones); and starved cells (thin cells, two to three days after the last divisions). Table 1 summarizes the results of their responses to 5 mM KOAc in the test arm for 30 min. The I_{che} of cells from different stages of growth were not significantly different. However, the cells in the medium-fed stage had a significantly higher I_m than other cells. Therefore, medium-fed cultures were routinely used for other experiments.

Table 1. Chemotaxis to KOAc of cells in three different growth conditions

| Growth Condition | I_{che} | I_m |
|------------------|-----------------|-----------------|
| well-fed | 0.86 ± 0.05 | 0.67 ± 0.03 |
| medium-fed | 0.87 ± 0.05 | 0.89 ± 0.05 |
| starved | 0.81 ± 0.06 | 0.66 ± 0.02 |

See *Material and Methods* for solution, procedures and definitions of I_{che} , I_m and growth conditions. Data are given as mean \pm standard deviation; number of experiments, $n = 4$.

Table 2. Chemotaxis to KOAc with three different densities of cells

| Number of animals per ml. | I_{che} | I_m |
|---------------------------|-----------------|-----------------|
| 200 | 0.89 ± 0.04 | 0.90 ± 0.08 |
| 500 | 0.91 ± 0.10 | 0.96 ± 0.02 |
| 700 | 0.89 ± 0.07 | 0.90 ± 0.07 |

See *Material and Methods* for solutions and procedures. Data are given as mean \pm standard deviation, $n = 4$.

Cell Densities. We found that the 100–200 fold dilution was crucial to dilute out as much culture medium as possible since the bacterized culture medium is a strong attractant. It is impossible to keep the dilution schedule fixed and yet use the same number of cells in each experiment. Therefore, to see if chemotaxis was affected by this varying cell density, we used the standard test with medium-fed cells responding to 5 mM KOAc for 30 min. No significant difference in the index of chemotaxis and the index of motility was observed using cells at 200, 500 or 700 cells per ml (Table 2). Lower densities increased the chance of error due to a small sample size. Therefore, for routine work, we ran tests with cells at about 500/ml. However, for slow-growing chemotactic mutants, it will be necessary to use lower densities (Van Houten, unpublished observation).

Repulsion. To demonstrate and quantify repulsion we put quinine-HCl in the test arm. Quinine-HCl was found by Dryl to repel paramecia (1973). In these experiments, Dryl's solution was used as the control solution. The test solutions consisted of various amounts of quinine-HCl dissolved in Dryl's solution. These tests were run for 30 min with medium-fed cells at around 500 cells/ml. Figs. 6a and 6b show the responses to such tests. There was a very strong repulsion at 0.001% quinine-HCl and complete repulsion at 0.01%. Control experiments with Dryl's solution gave $I_{che} = 0.51 \pm 0.04$ and $I_m = 0.35 \pm 0.09$ (0% quinine-HCl, Fig. 6). Motility, as indicated by I_m , did not change radically with the concentration of quinine-HCl. However, we found that the cells die in the test arms with more than 0.01% quinine-HCl. For standard demonstration of this repulsion, we used 0.005% quinine-HCl.

Countercurrent Separation Method

Attraction. When KOAc was added to one of the solutions, attraction to that solution was readily observed (Fig. 7). The optimal concentration of KOAc under

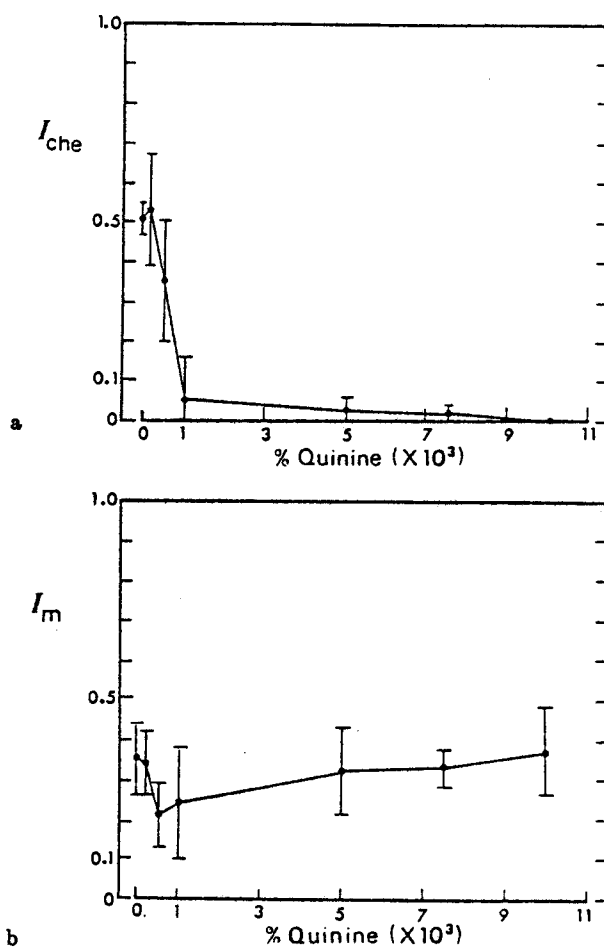

Fig. 6. (a) Repulsion from quinine-HCl in T-maze. Dryl's solution containing various concentrations of quinine-HCl is in the test arm. Dryl's solution is in the rest of the maze. $I_{che} < 0.5$ indicates paramecia being repelled from the test arm. $I_{che} = 0$ is complete repulsion. Mean \pm standard deviation; $n=8$. (b) Motility in quinine-HCl repulsion experiments. I_m indicates the fraction of paramecia moving out of the entry arm of the T-maze. Data collected from the same set of experiments in Fig. 6. Mean \pm standard deviation; $n=8$. See *Materials and Methods* for solutions, procedures and the definition of I_m and I_{che} .

these conditions was around 1 mM. At 1 mM KOAc, there was almost complete attraction (extent of chemotaxis=0.93). There was significantly less attraction to 0.1 mM and 10 mM than to 1 mM KOAc, as judged by the Mann-Whitney U Test. In these experiments the control solution was Dryl's solution without added KCl.

Attraction to 1 mM KOAc was also strong when the control solution contained 1 mM KCl in Dryl's solution (Fig. 8b). Here, the two solutions differed by only a single anion, acetate vs. chloride, as in the T-maze experiments above. In the countercurrent apparatus, paramecia were attracted to 1 mM KCl when this

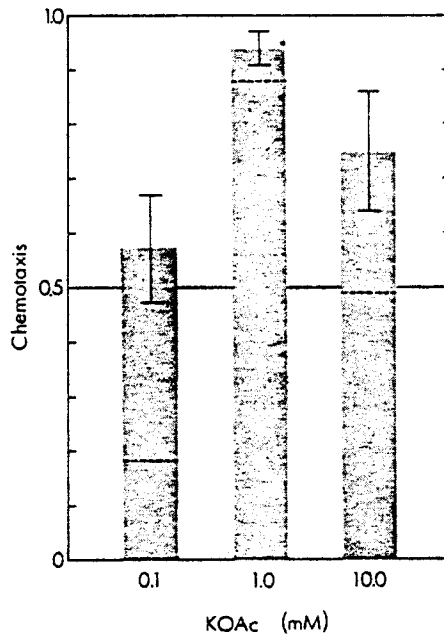

Fig. 7. Attraction to potassium acetate (KOAc) as assayed by counter-current separation. Extent of chemotaxis is defined in *Materials and Methods*; line at 0.5 represents value for no attraction or repulsion. Data are means \pm standard deviations. Indicated concentrations of KOAc were added to light solution of column 1 and dense solution of column 2. Broken lines across bars show fraction of cells in light (attractant-containing) solution of column 1 ($=I_1/(L_1 + D_1)$). For experiments in 0.1 mM, 1 mM, and 10 mM KOAc, n (number of experiments)=4, 10 and 5, respectively

solution was matched with Dryl's solution without KCl or KOAc added (Fig. 8c). This suggested that either potassium ion was an attractant or chloride ion was attractive although less so than acetate ion.

These data were obtained from experiments on cells in a variety of growth conditions. The number of cells injected ranged from 5,000 to 15,000. Considering these variations the standard deviations for the data are reasonably small for assays of behavior.

Repulsion. Negative chemotaxis was assayed in the countercurrent apparatus using 0.005% quinine-HCl. The extent of chemotaxis was 0.25 ± 0.09 , which indicated moderate repulsion. However, there were great discrepancies in the degree of repulsion when quinine-HCl was put into different layers. The cells avoided the quinine-HCl layer completely when the quinine-HCl was in the light layer ($L_1/(L_1 + D_1) = 0.005 \pm 0.004$, $n=5$). When quinine-HCl was in the lower, denser layer, only half of the cells avoided the quinine-HCl layer ($D_2/(L_2 + D_2) = 0.51 \pm 0.18$, $n=5$).

The presence of quinine-HCl causes the cells to jerk back and forth rapidly, so that they sink to the bottom of the tube. Thus, the extent of chemotaxis appears to be abnormally high (less repulsion) due to this artifact.

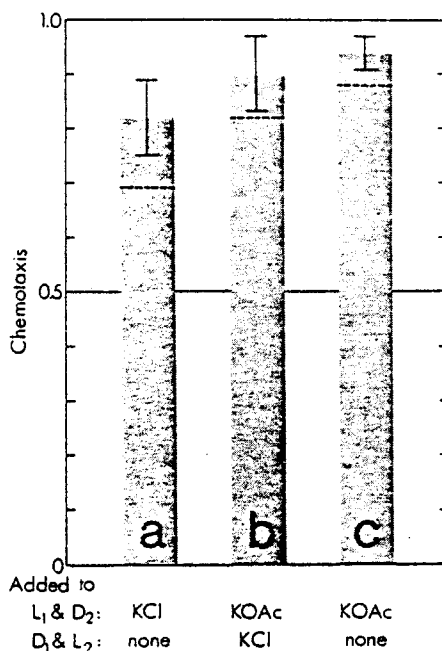

Fig. 8. Chemotaxis as assayed by countercurrent separation. For details, see legend of Fig. 7 and *Materials and Methods*. a) Extent of chemotaxis to KCl; $n=4$. b and c) Extent of chemotaxis to KOAc; $n=3$ and 10 , respectively. Concentrations of KCl and KOAc are 1 mM. Means are not significantly different by the Mann-Whitney U Test. D₁, L₁, D₂, L₂=dense and light solution of columns 1 and 2, respectively

Discussion

Both the T-maze and the countercurrent separation assay are sensitive and dependable methods to quantify attraction and repulsion in *Paramecium*. Each method has its own merits.

The T-maze was developed to provide a quick, quantitative assay. It is sensitive enough to detect the presence of 5 mM KOAc with 500 or fewer cells. Twelve T-maze assays can be completed within $1\frac{1}{2}$ hours including centrifuging the cells, setting up the T-mazes, and counting cells. Within-test variations, as shown by the standard deviations of I_{che} and I_m , are reasonable for behavioral assays.

I_{che} directly compares the numbers of cells entering the test arm and those entering the control arm. In a normal test population, the fractions of cells entering the three arms are homogeneous. For example, in a standard test, when the cells collected from the control arm were tested by a second T-maze, they gave the same I_{che} as the original population (Van Houten, unpublished observations). Thus, although I_{che} was derived from data of populations, it measures the probability of an individual cells' moving into the test solution over the control solution. This probability determines the strength of chemotaxis.

I_m is a more complicated index. At present it is a check on the viability of cells; those populations showing unusually low I_m are suspected of being damaged in centrifugation. However, even with healthy cells, I_m varies with the ionic strength

of the solutions used. From the volumes of the arms, one expects an I_m of 0.83 if the cells distribute by random walk through the T-maze. When 5 mM KCl fills all arms of the T-maze, the $I_m = 0.76 \pm 0.09$ (Fig. 4), which is consistent with the figure above. However, $I_m = 0.25 \pm 0.04$ (Fig. 4) and $I_m = 0.35 \pm 0.09$ (Fig. 6) when 10 mM KCl and Dryl's solution respectively are used. This failure to move out of the entry arm, E, may be due to stoppage on the walls of the T-maze (thigmotactic behavior (Jennings, 1967)), or to the high Donnan ratio ($K^+/\sqrt{Ca^{++}}$) which changes the frequency of ciliary beating (Eckert, 1972), and, hence, motility and I_m .

If the cells that enter the test arm, T, with attractant remain in the test arm, then one expects an even higher I_m for T-mazes run with attractant in the test arm than with control solutions in all arms. The test arm in effect removes cells from the E and C arms, and there are fewer cells left to distribute throughout the T-maze. Hence, we expect I_m to be greater than 0.83. The average I_m does rise with increasing concentration of attractant in the test arm up to 5 mM (Fig. 4). However, the I_m of the cells in the T-mazes with control solution in all arms rises parallel to the rise of the I_m with increasing concentration of attractant (Fig. 4). The large variation in the data may be obscuring the effect of the attractant on the I_m . Because in these solutions the I_m is already high (at 5 mM KOAc $I_m = 0.87$, 5 mM KCl $I_m = 0.76$), a small increase in I_m may have been overlooked. A stronger attractant may help clarify this point.

The countercurrent separation method was developed to deal with large populations. For our work in *Paramecium*, some changes of the original design for nematodes were necessary.

The optimal viscosity and salt concentration for motility and survival of *Paramecium* are much lower than those for nematodes, so that the solutions used were quite different. Because of the lower viscosity of the solutions for *Paramecium*, higher flow rates (0.7 ml/min) and shorter tubes were used to avoid excessive mixing of the solutions. It was observed, however, that the paramecia could easily swim across the boundary from one solution to the other when each solution was flowing at this rate; and strong chemotactic responses were measured, as shown in Figs. 7 and 8. The dashed line across each bar in Figs. 7 and 8 indicates the fraction of cells emerging in the light (attractant-containing) layer of column number 1 ($=L_1/(L_1 + D_1)$). This value is always less than the mean. Since the cells tended to sink in these solutions, there was always a larger fraction of cells in the attractant layer when the attractant was in the dense solution.

This sinking was most obvious when quinine-HCl was used. The tendency to sink biased the measured extent of chemotaxis. This explains why the extent of chemotaxis to quinine-HCl is higher in the counter-current apparatus (0.25 ± 0.09) than in the T-maze (0.06 ± 0.04). For this reason, the countercurrent apparatus is probably not as useful as the T-maze for measuring repulsion in *Paramecium*.

After the effluent solutions were collected for 40 min, there was an average of 10–15% of the cells remaining in the tube. The number of cells remaining was highly variable, however, ranging from less than 1% to 50%. The fraction of cells remaining in the tube did not correlate with the extent of chemotaxis, the number of cells injected, or the growth conditions of the cells. This variable remains unexplained.

Using eight pump channels, one can run four tubes (two experiments) simultaneously. The time required for preparation and cell counts is 30 to 40 min per experiment. This assay is, therefore, much slower than the T-maze assay; but it is also less dependent upon cell motility. Since large numbers of cells are used, the countercurrent apparatus is suited to the isolation of chemotactic mutants. The estimated frequency of such mutants in a mutagenized population is on the order of 10^{-4} . The countercurrent apparatus, among other methods, has been used to screen mutagenized populations of *P. aurelia* for variants that do not show chemoaccumulation to KOAc. Among 4 variants found, one was obtained with the countercurrent screening method. Thus, this apparatus has proved successful both for quantitating positive chemotaxis and for isolating chemotactic variants of *Paramecium*.

The two methods used in this study have some basic differences. In the T-maze a chemical gradient must have developed from the test arm to the entry arm in order to attract or repel the cells. Responses to gravity or fluid current are not involved. However, this method depends on the ability of the cells to swim in the gradient. Thus, motility becomes important and complications due to stoppage may arise. The countercurrent method provides a large boundary between the two solutions relative to the depths of the solutions. Cells are exposed to this boundary when they are injected into the tube, even if they do not swim very actively. However, this method is complicated by sinking and geotaxis, the effects of which cannot always be cancelled out by paired reciprocal experiments, as shown by the results of the quinine-HCl repulsion experiments.

This study is on new methods to quantify chemotaxis. The behavioral mechanisms by which the cells are repelled or attracted were not analyzed here. The importance of avoiding reactions, adaptation, velocity modulations and stoppage in relation to positive and negative chemotaxis will be dealt with elsewhere. We have used the term "chemotaxis" strictly as an operational and generic term without implying its mechanism.

Although the mechanism of chemotaxis is not immediately obvious from the assays, the two new assays developed in this study now make possible the reliable and truly quantitative measurement of attraction and repulsion in *Paramecium*.

The authors are grateful to S.-Y. Chang and P. Foletta for their very capable technical assistance. This work was supported in part by grants from the U.S. Public Health Service and National Science Foundation to C.K.

References

- Adler, J.: Chemoreceptors in bacteria. *Science* 166, 1588-1597 (1969)
- Adler, J., Hazelbauer, G.L., Dahl, M.M.: Chemotaxis toward sugars in *Escherichia coli*. *J. Bact.* 115, 824-847 (1973)
- Dahlquist, F.W., Lovely, P., Koshland, D.E.: A quantitative analysis of bacterial migration in chemotaxis. *Nature (Lond.)* 236, 120-123 (1972)
- Dryl, S.: Antigenic transformation of *Paramecium aurelia* after homologous antiserum treatment during autogamy and conjugation. *J. Protozool.* 6, Suppl. 25 (1959)
- Dryl, S.: Contributions to mechanism of chemotactic response in *Paramecium caudatum*. *Anim. Behav.* 11, 393 (1963)
- Dryl, S.: Chemotaxis in ciliate protozoa. In: *Behavior of micro-organisms* (Perez-Miravete, A. ed.), p. 16-30. New York: Plenum Press 1973

- Dusenbery, D. B.: Countercurrent separation: a new method for studying behavior of small aquatic organisms. *Proc. nat. Acad. Sci. (Wash.)* 70, 1349-1352 (1973)
- Dusenbery, D. B.: Analyses of chemotaxis in the nematode *Caenorhabditis elegans* by counter-current separation. *J. exp. Zool.* 188, 41-48 (1974)
- Eckert, R.: Bioelectric control of ciliary activity. *Science* 176, 473-481 (1972)
- Fraenkel, G. S., Gunn, D. L.: *The orientation of animals*, p. 10. New York: Dover Publications Inc. 1961
- Hazelbauer, G. L., Mesibov, R. E., Adler, J.: *Escherichia coli* mutants defective in chemotaxis toward specific chemicals. *Proc. nat. Acad. Sci. (Wash.)* 64, 1300-1307 (1969)
- Jennings, H. S.: *Behavior of the lower organisms*, p. 61. Bloomington: Indiana Univ. Press 1967
- Konijin, T. M., van de Mune, J. G. C., Bonner, J. T., Barkley, D. S.: The acrasin activity of adenosine-3', 5'-cyclic phosphate. *Proc. nat. Acad. Sci. (Wash.)* 58, 1152-1154 (1967)
- Kung, C., Chang, S.-Y., Satow, Y., Van Houten, J., Hansma, H.: Genetic dissection of behavior in *Paramecium*. *Science* 188, 898-904 (1975)
- Nakatani, I.: Chemotactic response of *Paramecium caudatum*. *J. Fac. Sci. Hokkaido Univ., Ser. VI Zool.* 16, 553-563 (1968)
- Nakatani, I.: Effects of various chemicals on the behavior of *Paramecium caudatum*. *J. Fac. Sci. Hokkaido Univ., Ser. VI Zool.* 17, 401-410 (1970)
- Sonneborn, T. M.: *Methods in the general biology and genetics of Paramecium aurelia*. *J. exp. Zool.* 113, 57-145 (1950)
- Tsang, N., McNab, R., Koshland, D. E.: Common mechanism for repellents and attractants in bacterial chemotaxis. *Science* 181, 60-63 (1973)
- Wilkinson, P. C.: *Chemotaxis and inflammation*. London: Churchill Livingstone 1974

Judith Van Houten
Helen Hansma
Department of Biological Sciences
University of California
Santa Barbara, California 93106, USA

Ching Kung
Laboratory of Molecular Biology and
Department of Genetics
University of Wisconsin
Madison, Wisconsin 53706, USA